

Installing Wall Paneling (1 – Nails or 2 - Adhesive)

Any of our plywood panels may be installed on plaster or gypsum wallboard walls and our 5.2mm (1/4") paneling may be installed directly to studs or furring strips, since it has structural strength. For 2.7mm or 3.6mm paneling, exposed studs need to first be covered with gypsum board to provide a firmer, smoother surface for paneling; you will be happier with the quality of the paneling job!

Also, paneling may be applied with nails or panel adhesive. The advantage of using adhesives is that the panel surface is unmarked by depressions that result from the use of nails and, therefore, adhesives typically give a better appearing job. Trim molding may also be applied with paneling adhesive.

Before beginning to install your paneling, read through these instructions and assemble the recommended tools and supplies. Also, determine in advance of the installation where and how you are going to use trim molding as this has an impact on where your installation begins and ends.

Cutouts for electrical switch plates and outlets, doors and windows must be made BEFORE each panel is installed. If molding is to be installed along the ceiling edge, leave about 1/4" gap between the top of the panel and the ceiling[1]. If not installing molding here, place the panel against the ceiling. Ref28

Recommended Tools and Supplies

The following tools and supplies are useful for installing veneered or laminated plywood sheet panels:

Claw Hammer	Keyhole Saw
Nail Set	Coping Saw
Common, Flat Screw Driver	Drill
Wood Rasp	Wood Blocks (e.g., 2" x 4")
Tape Measure	Nails (see below*) and/or Paneling Adhesive/Caulk Gun
Carpenter's Level	Plumb Line device
Carpenter's Square	Sandpaper, medium grit
<i>Any one of:</i> Hand, Table, Radial Arm, Portable Circular, or a Sabre Saw	

Installing Veneered or Laminated Plywood Wall Panels With Nails

*Surface	*Suggested Nails
Furring Strips, studs, backing board	3 penny (1 1/4") Finishing nails and putty -or- 1" colored nails
Gypsum wallboard or plaster	6 penny (2") Finishing nails and putty -or- 1 5/8" colored nails
Molding and trim	3 penny (1 1/4") Finishing nails and putty -or- 1 5/8" colored nails

Finishing nails should be carefully countersunk 1/32" with your nail set and avoid damaging the paneling surface. A wood putty that blends with the panel finish is recommended to fill countersunk nail holes and if you use colored nails, do not countersink them. Take extra care not to dimple the paneling surface as you drive the nail with your hammer or nail set.

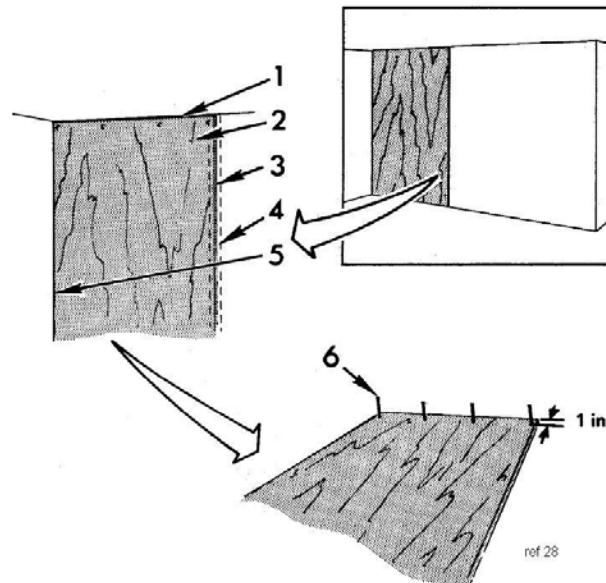

Normally starting in a corner, the first panel should be installed so that the leading edge[3] (the edge not in the corner) is on-center of a stud[4] or furring strip[4], and it is critical that the first panel on the wall be perfectly plumb. Mark the center of the stud with a plumb line. With the position of the panel leading edge determined, trim the edge of the panel that will fit into the corner so the panel fits into the corner, and note that your wall/corner may not be plumb! If you are using corner trim, leave about a $\frac{1}{4}$ " gap. Ref28

- 1 – Trim the panel so one edge[5] fits into the corner, and the other edge[3] aligns perfectly with the plumb line mark on the stud
- 2 – Drive four nails part way into the panel (not into the wall) about 1" from the top edge[6]
- 3 – Place the panel at the installed position, pushing against the previous panel
- 4 – While holding the panel in position, drive the four nails[6] completely into the wall

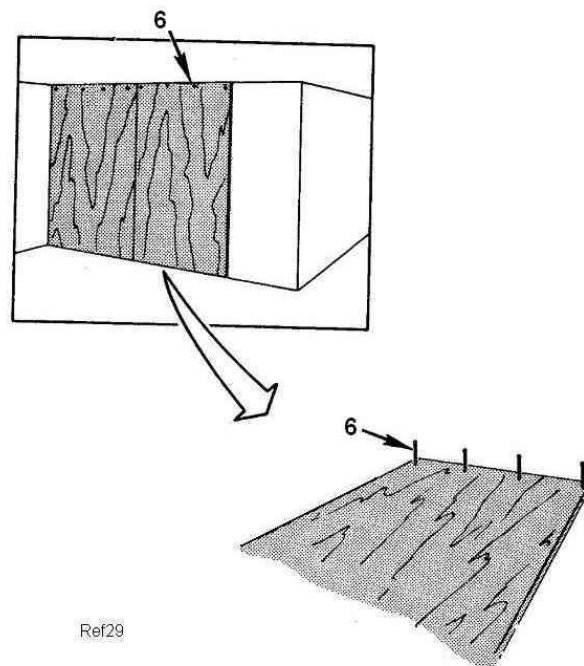

Installing the middle panels Ref29

- 1 – Repeat steps 2-4 from above for additional panels, except for the last panel on each wall

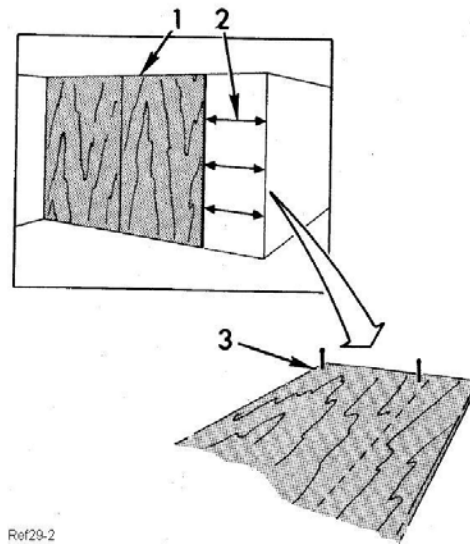

Installing the last panel on each wall with nails Ref29-2

- 1 – Measure and record the distance between the installed panel and the corner, at several places[2]
- 2 – Beginning at the edge of the last panel, measure and mark distances you just recorded
- 3 – Using measured marks as a guide, draw a reference line on the 'last' panel
- 4 – Cut the panel and 'dry-fit' the panel in position
- 5 – If panel doesn't fit, trim it until it fits, then sand the cut edge lightly
- 6 – Drive two nails into the top edge[3] and position the last panel in place
- 7 – Push the last panel against the previous panel, then drive the two nails into the wall

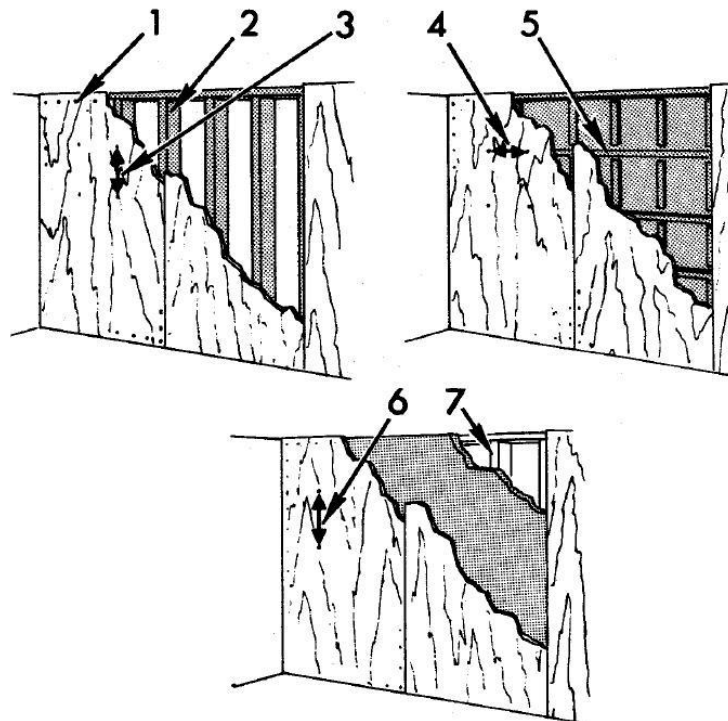

Spacing of additional nails on partially installed panels. Ref30

If installing onto studs:

- 4-inch intervals along four edges[1]
- 12-inch intervals into studs[2,3]

If installing onto horizontal furring strips:

- 4-inch intervals along four edges[1]
- 16-inch intervals along horizontal furring strips[4,5]

If installing directly onto a wall, be sure that nails hit studs, and space as follows:

- 4-inch intervals along all four edges[6]
- 16-inch intervals at each wall stud[7]

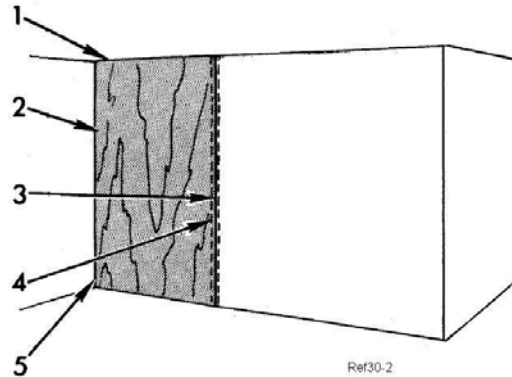
**Installing Veneered or Laminated Paneling with Adhesive Ref30-2**

After cutouts for electrical switch plates, outlets, doors and windows are made, If trim molding is to be installed along the ceiling, leave ¼" gap [1] between top of panel [2] and ceiling. If not installing molding, place panel against ceiling.

If panels will be fastened with adhesive, the edges of the paneling may sometimes separate from the wall. Separation can occur as a result of improper application of panel adhesive. So that edges of panels can be attached to wall with nails if adhesive fails at a later time, it is a good idea for edges[3] to be located on centers of studs[4] or furring strips.

The first panel must be plumb. Therefore, the wall must be marked with a plumb line for aligning the leading edge[3] of the panel. Edge[5] and [2] must fit into the corner, and may need to be trimmed if the corner itself is not plumb.

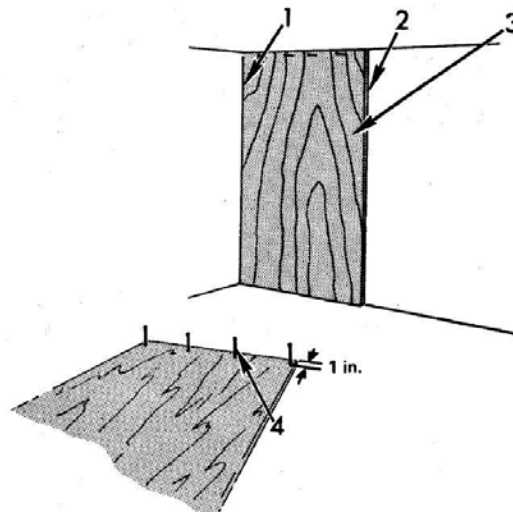
**Installing first panel on the wall with adhesive [above]**

- 1 – Trim panel edge[1] so that it fits into the corner well, and that edge[2] aligns with plumb line (on stud if possible)
- 2 – Drive four 3-penny (1 ¼") finishing nails[4] partway into panel [3] 1" from the top edge

- 3 – Following manufacturer's instructions, apply panel adhesive to wall, studs or furring strips. Starting in the corner, run a small bead of adhesive along the studs, furring, or if you are installing on solid wall, apply adhesive in a grid pattern. Do not apply adhesive beyond area to be covered by panel.
- 4 – Place panel [3] at installed position and press lightly to spread adhesive to back of paneling
- 5 – While holding at installed position, drive four nails[4] ¼" to 1/2" into the wall, leaving enough of nail exposed for easy removal

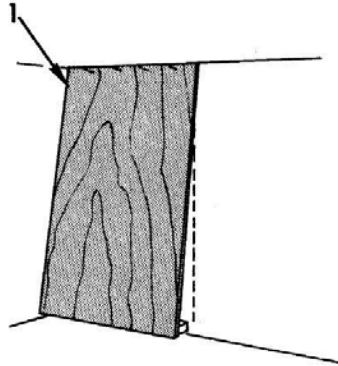

- 6 - If adhesive instructions suggests this(and most do), pull bottom of paneling away from the wall until it becomes tacky, using scrap wood at the bottom as a spacer. Once tacky, remove the scrap wood and press paneling firmly into wall, then, using a fabric-wrapped block of wood against the paneling to protect it, use the hammer to carefully set the paneling against the wall. We recommend driving nails at 6 to 12" spacing along the top and bottom edges of the paneling, but this is optional.
- 7 – Countersink any nails with your nail set, and fill any nail holes with a color-matched putty and wipe off any exposed adhesive

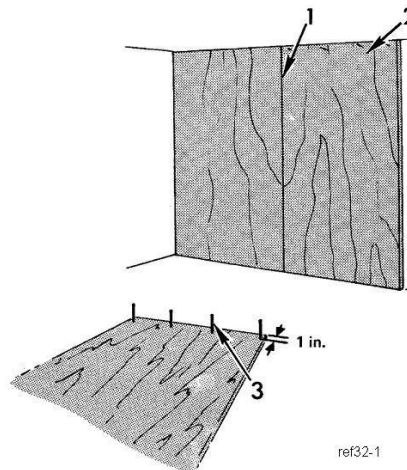

Installing middle panels with adhesive ref32-1

- 1 – Repeat steps 2 through 7 except for the last panel

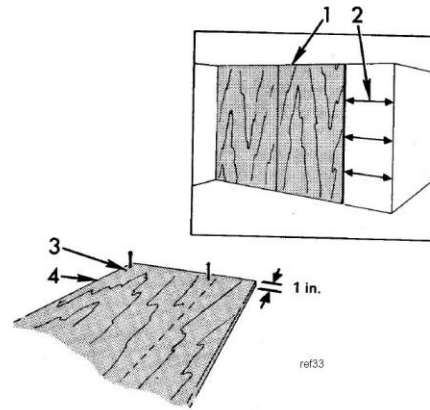

Installing the last panel on each wall, with adhesive

- 1 - Measure and record distance[2] from panel[1] and corner at several places
- 2 - Beginning at edge[4], measure and mark distances recorded in Step 1
- 3 - Using marks as a guide, draw a line on panel, and cut to size to fit corner. Sand edge
- 4 - Drive two 3-penny nails part-way into top of paneling, 1" from top edge
- 5 - Repeat Middle Panel steps 2-7 for the last panel, as well.